



### Alloy Mallet

This will make light work of securing your stakes into the ground. It's lightweight but packs a heavy punch.

#### Key Features:

- Large head diameter
- Easy to carry and swing
- Easy for inexperienced operators to use
- Less tiring to use even over long periods
- Alloy head won't chip, burr or damage stakes
- The alloy head will be kind to your alloy leg extrusions
- Alloy head means no risk of sparking

#### Specifications:

- Weight: 4.6kg
- Head dia: 100mm
- Material: high strength billet alloy
- Handle: nylon reinforced fibreglass



Standard Stake Puller



Structure Stake Puller



### Stake Puller

The fastest tool on the market for removing large numbers of stakes. Available in two options: Standard for regular stakes and Structure for structure stakes.

#### Key Features:

- One piece design with interchangeable heads for different stake diameters
- Works on pillar jack principle
- Lightweight, easy to carry and move
- Large stable base won't sink into soft ground
- Ergonomically designed to minimise back strain
- Structure puller has extra tongue to lever base plates

#### Specifications:

- Leverage: 10:1 (approx)
- Weight: 11.5kg
- OA Height: 1600mm (63")
- Material: Galvanised steel

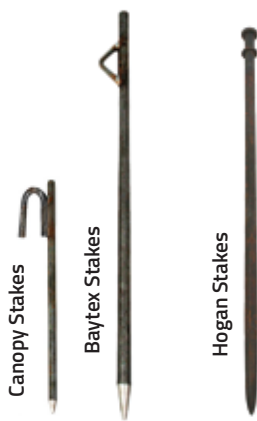

Canopy Stakes

Baytex Stakes

Hogan Stakes

### Marquee & Structure Stakes

Baytex offers a selection of stakes for canopies, marquees and structures.

#### Canopy Stakes Key Features:

- Ideal for canopies
- Economical
- Machined and fabricated from mild steel bar
- 550mm x 15mm unrated

#### Baytex Stakes Key Features:

- Ideal for pole marquees, smaller frame marquees and canopies
- Also suitable for large frame marquees and structures
- Economical
- Machined and fabricated from mild steel bar
- 850mm x 24mm
- nom pull-out capacity 400kg, nom rated capacity 200kg

#### Hogan Stakes Key Features:

- Ideal for larger frame marquees and structures
- Will not bend or loose their points
- Made from high tensile steel
- 760mm x 25mm, nom pull-out capacity 500kg, nom rated capacity 250kg

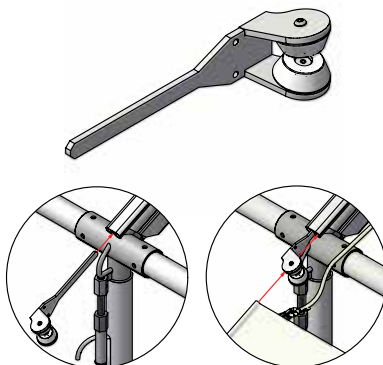

### Keder Feeder - Frame & Structure

Ease on your roofs pulling them through evenly.

#### Key Features:

- Helps protect the keder and PVC
- Takes the drag off pulling the PVC directly through the alloy extrusion

## Accessories

SIMPLICITY · PERFORMANCE · STYLE





### Staking Plate

The simple and effective way to increase the holding capacity of your stakes.

#### Key Features:

- Increase stake capacity by 2x with 2 stakes
- Increase stake capacity by 2.5x with 3 stakes
- Economical and simple design
- Low profile to minimise trip hazard
- Effective and easy to use

#### Specifications:

- Dimensions: 750mm L with 3 holes at 40mm dia
- Material: 50mm x 75mm MS angle
- Finish: Hot dip galv



### Ratchet Strap

The compact and strong tensioning mechanism.

#### Key Features:

- Effective and easy to use
- Load binder tensioning mechanism for easy tension adjustment
- Compact and strong
- PVC cover for tensioning mechanism
- Certified load rated

#### Specifications

- Strap RS50 - 50mm, 4.2m long, White
- Nom load capacity 1500kg
- Strap RS35 - 35mm, 4.2m long, White
- Nom load capacity 1000kg



### Sliktop PVC Cleaner

PVC Fabric Conditioner and Cleaner specially formulated PH neutral cleaner for all PVC fabrics including marquees, tents, canopies and side walls.

Sliktop is a Phosphate free, non toxic and biodegradable by microbial action and provides an excellent cleaning performance while protecting valuable PVC surfaces when used as instructed.

- Use 50:1 ratio for a normal clean
- Use 10:1 for spot cleaning



### Doorset

Create a formal entrance way with our Doorset. Stainless kick plates, stainless handles and air springs for soft closing gives class and distinction to your Marquee or structure. A minimum leg height of 2.4m is required for use of the doorset.

#### Options:

- Double Door set - 1850mmW x 2050mmH x opening size
- Single Doorset - 95mmW x 2050mmH x opening size
- Emergency Exit Doorset with panic mechanism

#### Key Features:

- Quick and easy to install with two people
- Heavy duty fibreglass finish with wood core construction
- White painted fibreglass doors are chip resistant and dent resistant
- Tempered, double glazed glass inserts
- Automatic door closers fitted as standard
- Rigid steel and alloy door frame securely holds each door



#### New Zealand

52 Newton Street,  
PO Box 4370, Mount Maunganui  
New Zealand

tel +64 7 579 0190  
info@baytex.co.nz  
www.baytex.co.nz

#### Australia

tel 1800 766 661  
info@baytex.com.au  
www.baytex.com.au

