

# TRACK

## Lining Instructions

---



SIMPLICITY · PERFORMANCE · STYLE

---

### New Zealand

52 Newton Street,  
PO Box 4370, Mount Maunganui  
New Zealand

tel +64 7 579 0190  
fax +64 7 579 0194  
[www.baytex.co.nz](http://www.baytex.co.nz)

### Australia

tel 02 4340 4144  
mob 0400 312 314

# A-Frame Pull Thru Lining Installation

## 1. Configuration Options

- 1A. 2 Piece Mid Liner  
- 2 piece Gable Liner
- 1B. 4 Piece Mid Liner  
- 4 piece Gable Liner

End Mid Panels required where Gables to be installed

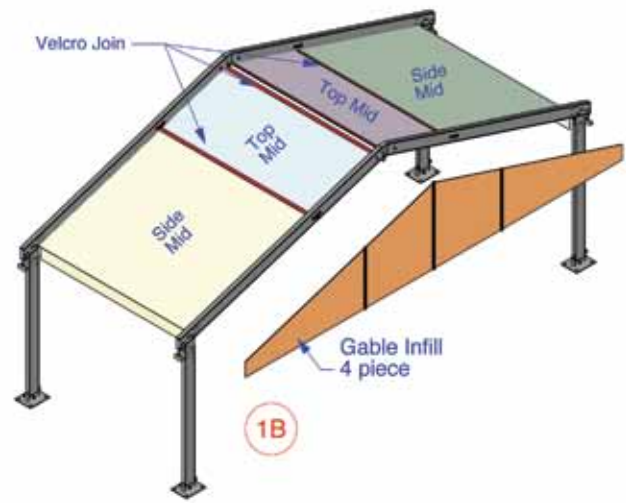
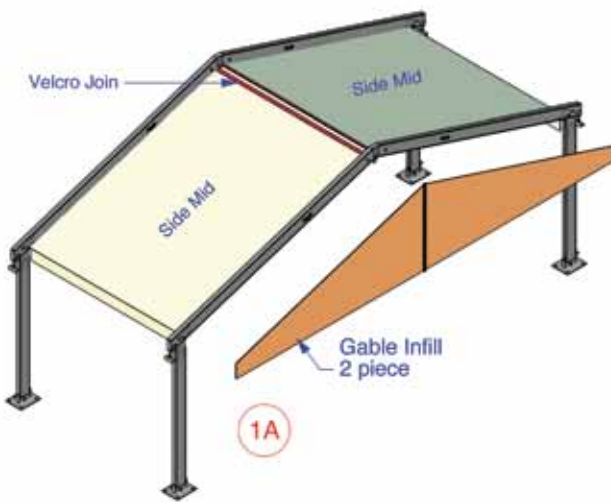
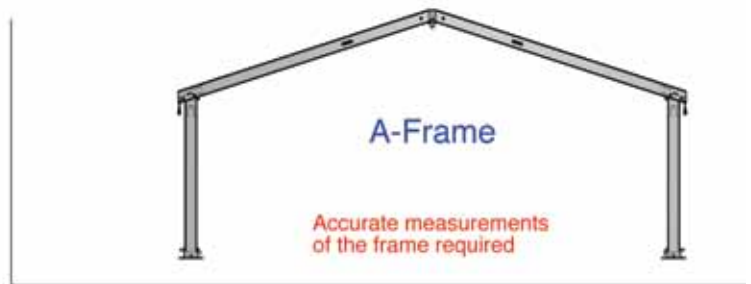

## 2. General Installation

- 2A. Attach pull ropes
- 2B. Liners pull through lower rafter track  
- Pull Evenly
- 2C. Fasten Sister Clips and Velcro joins  
- eg: Side Mid to Top Mid
- 2D. Gables tensioned at Eave Level  
with Camlock Buckle and web strap

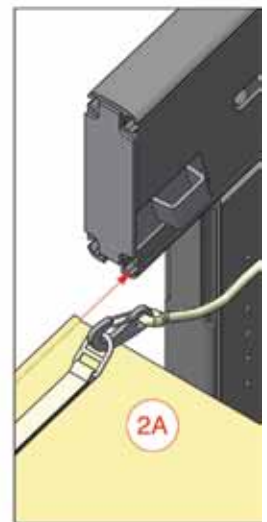
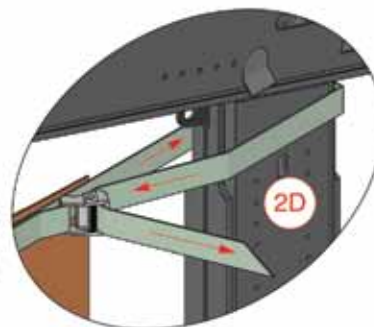
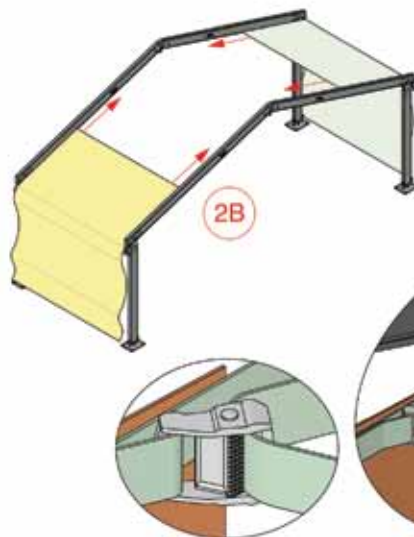

## 3. Eave Tension Systems

- 3A. P1 Style Eave  
- Web Strap around Eave Bar  
- Fasten Side Release Buckle
- 3B. P2 Style Eave  
- Structure Hook & Bungy Cord  
- Hook into Eave Extrusion track
- 3C. Attach Hooks at End of Bungy

Eave tension critical for smooth look to Flat Liners

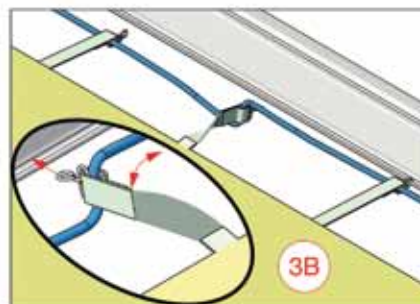
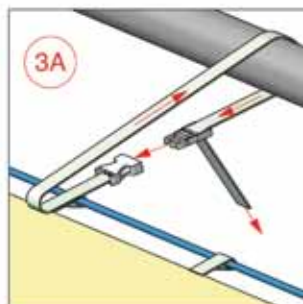

# Curved Top Pull Thru Lining Installation

## 1. Configuration Options

- 1A. 1 Piece Mid Liner  
- 2 piece Gable Liner
- 1B. 2 Piece Mid Liner  
- 2 piece Gable Liner
- 1C. 3 Piece Mid Liner  
- 3 piece Gable Liner
- 1D. 4 Piece Mid Liner  
- 4 piece Gable Liner

End Mid Panels required where Gables to be installed

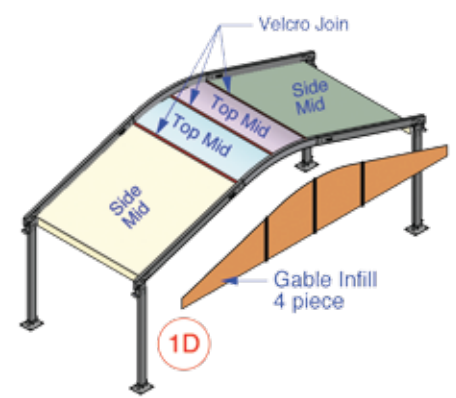
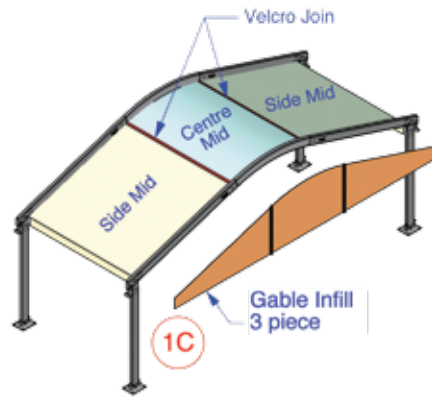
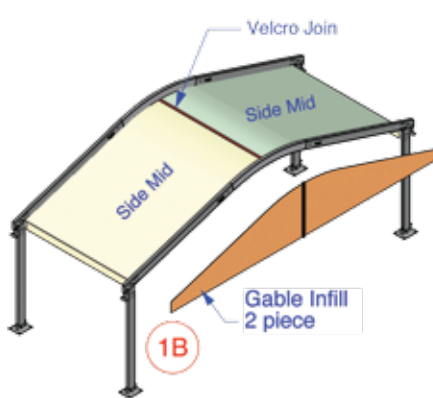
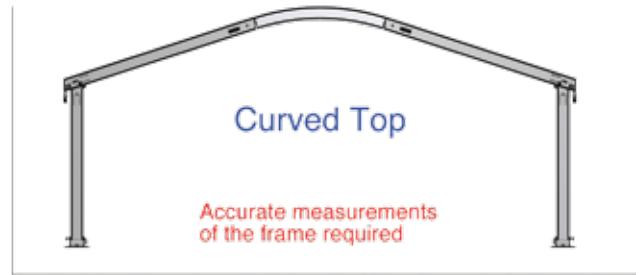
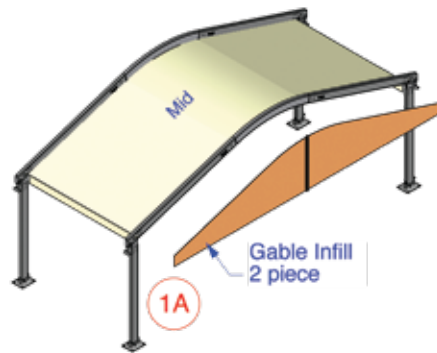

## 2. General Installation

- 2A. Attach pull ropes
- 2B. Liners pull through lower rafter track  
- Pull Evenly
- 2C. Fasten Sister Clips and Velcro joins  
- eg: Side Mid to Centre Mid
- 2D. Gables tensioned at Eave Level  
with Camlock Buckle and web strap

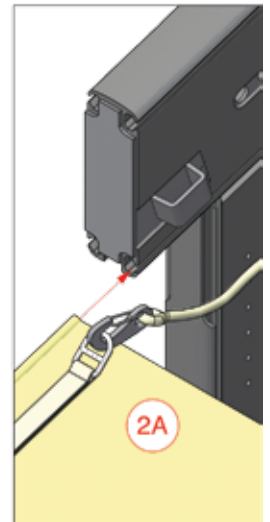
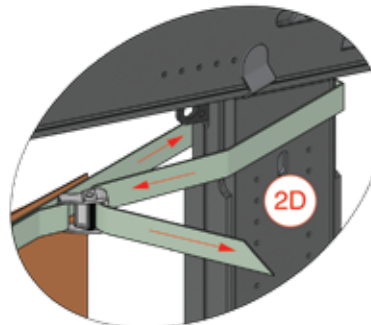
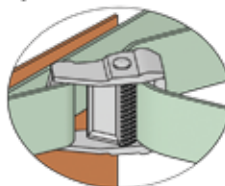
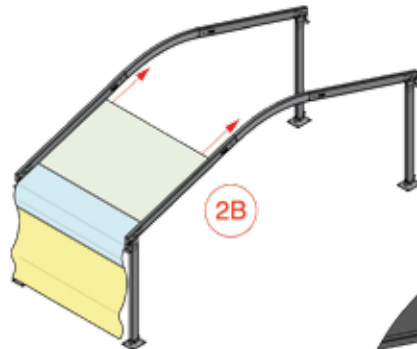

## 3. Eave Tension Systems

- 3A. P1 Style Eave  
- Web Strap around Eave Bar  
- Fasten Side Release Buckle
- 3B. P2 Style Eave  
- Structure Hook & Bungy Cord  
- Hook into Eave Extrusion track
- 3C. Attach Hooks at End of Bungy

Eave tension critical for smooth look to Flat Liners

