

PE18 specifications

- Aircraft-quality cast aluminium 356 alloy
- Heat-treated to T6 specification
- Install with 1" socket
- Removable

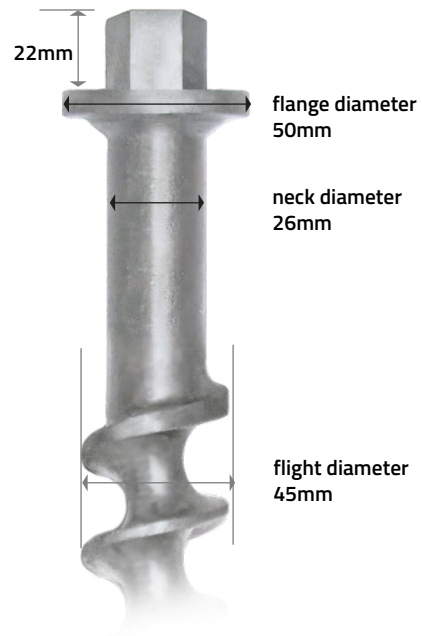
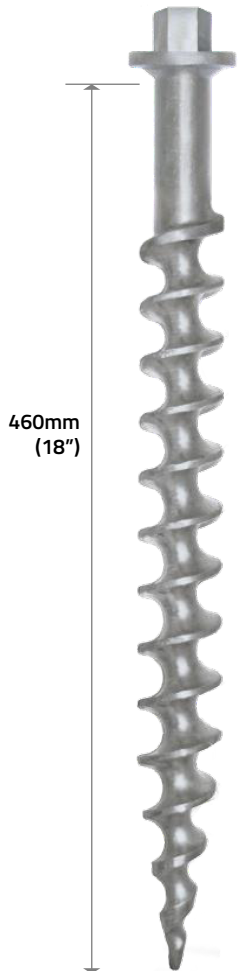
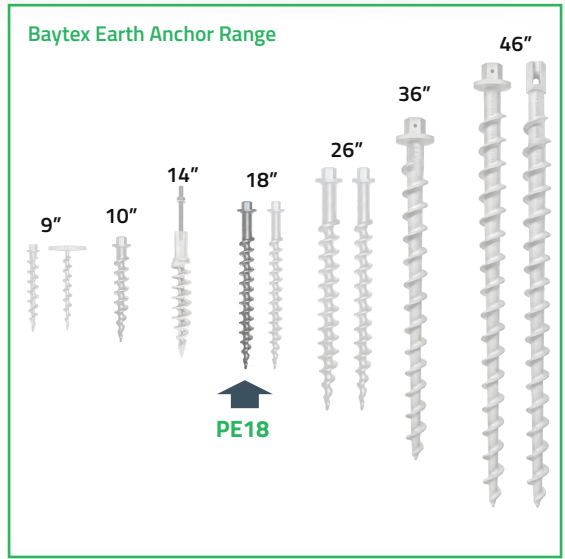

6-point socket (instead of a 12-point socket) will minimise wear and rounding of hex head for repeated installation/removal

LOAD CAPACITY
Pullout strength with flight fully embedded



| SOIL CLASS | LOAD CAPACITY |
|-------------------------------|-------------------------|
| 1 hardpan/asphalt/clay | 11.1kN (1311 kg) |
| 2 Cohesive soil | 7.56 kN (771 kg) |
| 3 Medium density soil | 2.67 kN (272 kg) |
| 4 Loose med-to-fine sand | 1.56 kN (159 kg) |
| 5 Loose fine uncompacted sand | 0.89 kN (91 kg) |

PE18
46cm (18")

Earth Anchors - PE18

SIMPLICITY · PERFORMANCE · STYLE



PE18 installation



Pre drill pilot hole with impact wrench (this determines holding power). Earth Anchor can then be installed.

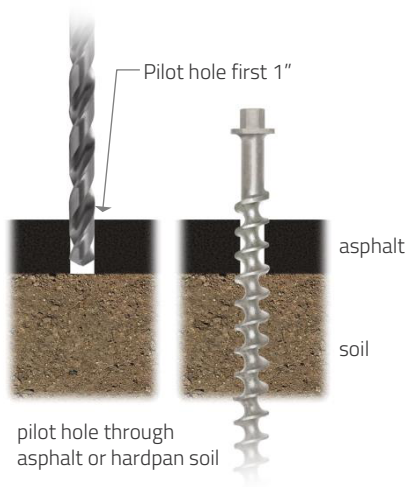

pilot hole through asphalt or hardpan soil

install at same angle as load for maximum pullout strength

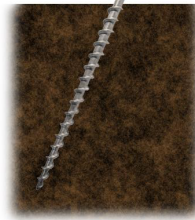

non-vertical load

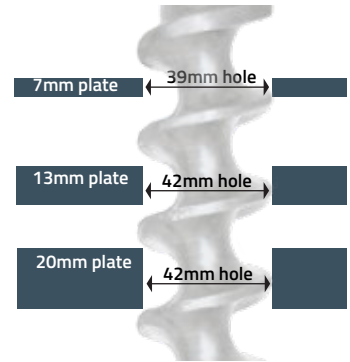

through a metal plate

accessories sold separately

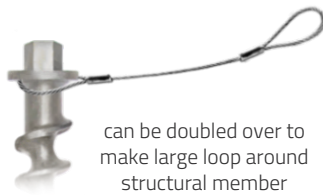

can be doubled over to make large loop around structural member



10" Tie-off cable

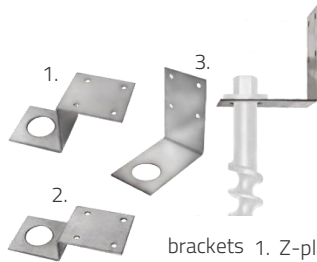

brackets 1. Z-plate 4x4
2. Z-plate 4x2
3. L-bracket



installation tools

adaptor
socket
soil auger 1 1/16"
or asphalt/hardpan/clay auger 1"

application suggestions



beach shelter



pop-up tents



bench seats/outdoor furniture



awnings



trampolines

New Zealand

52 Newton Street,
PO Box 4370, Mount Maunganui
New Zealand

Australia

tel +64 7 579 0190 tel 02 4340 4144
fax +64 7 579 0194 www.baytex.com.au mob 0400 312 314
co.nz

